

PLAYGROUND SPIELPLATZ

PLAC ZABAW AIRE DE JEUX

(305 x 253 x h240cm)

003_00650_02062021

MOVE PLUS

INSTALLATION INSTRUCTIONS
MONTAGEANLEITUNG

INSTRUKCJA MONTAŻU
GUIDE D'INSTALLATION

Warranty period - 2 years from purchase date

Garantiezeit - 2 Jahre ab Kaufdatum

Okres gwarancji - 2 lata od momentu zakupu towaru

Période de garantie - 2 ans à compter de l'achat

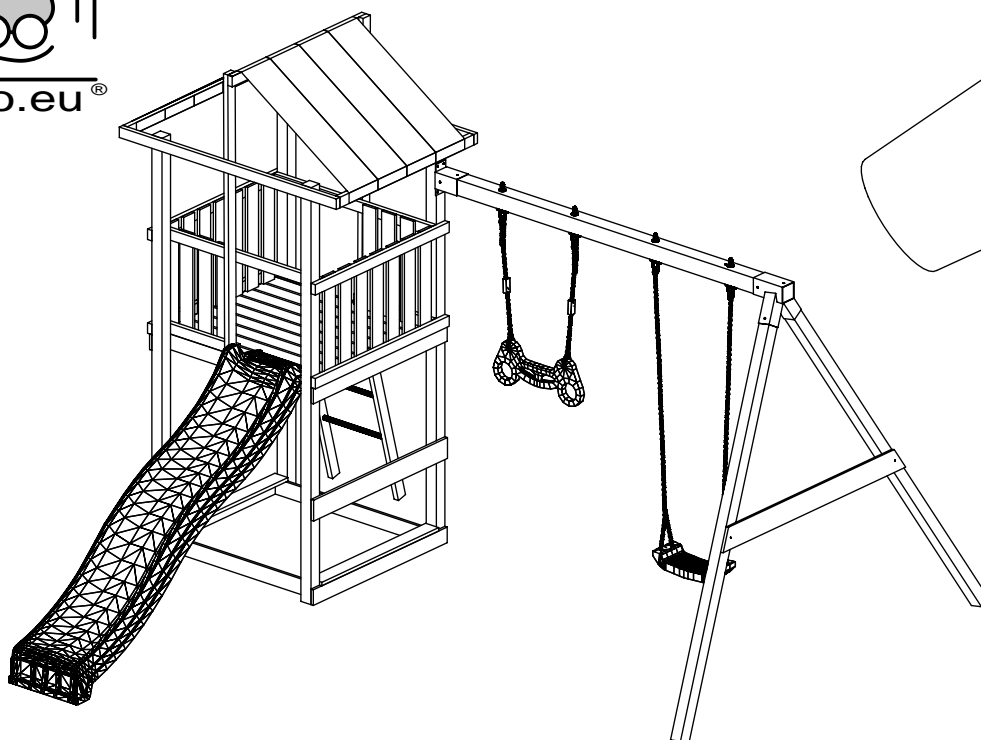

CE
EN - 71

WARNINGS!

Only for home use.

Dedicated for external use only.

Not suitable for children under 3 years old.

Risk of falling down and/or hitting.

Maximum user weight is up to 50 kg.

Maximum number of users staying on the playground at the same time: 2.

OSTRZEŻENIA!

Tylko do użytku domowego.

Przeznaczony do użytku na zewnątrz.

Nie przeznaczony dla dzieci poniżej 3 roku życia.

Niebezpieczeństwo upadku i/lub uderzenia.

Maksymalna waga użytkownika to 50 kg.

Maksymalna liczba użytkowników przebywających na placu zabaw w tym samym czasie: 2.

ACHTUNG!

Nur für den privaten, häuslichen Bereich.

Ausschließlich für die Verwendung im Freien.

Nicht geeignet für Kinder unter 3 Jahren.

Stolper- und / oder Sturzgefahr

Höchstgewicht pro Einzelkind beträgt 50 kg

Der Aufenthalt auf diesem Spielturm ist max. : 2.

Kindern gleichzeitig erlaubt.

AVERTISSEMENT!

Aire exclusivement destinée à un usage privé.

Aire exclusivement destinée à un usage en extérieur.

Prévue pour les enfants de plus de 3 ans.

Danger de chute ou de choc.

Poids maximal d'un utilisateur : 50 kg.

Nombre maximal d'utilisateurs présents en même temps sur la même aire de jeux: 2.

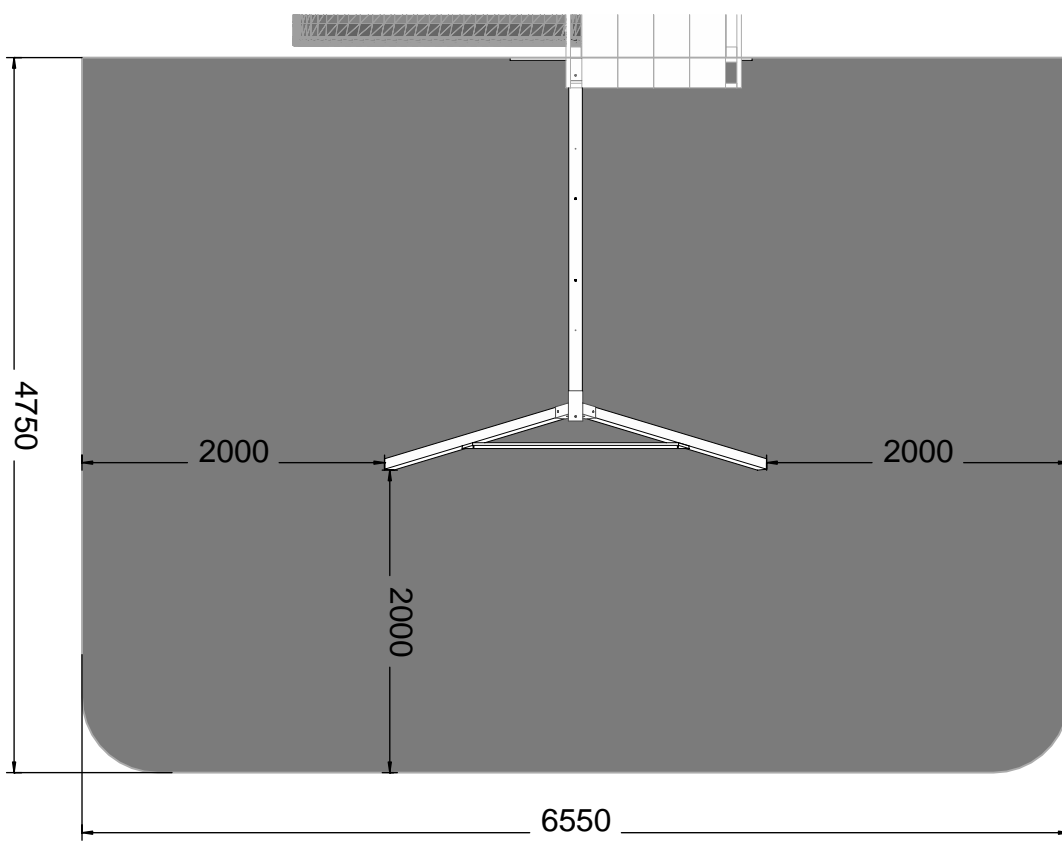

(W80) x8

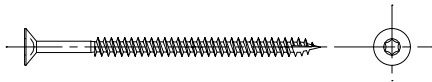

(T80) x4

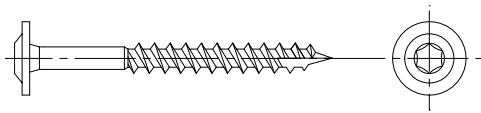

(T60) x17

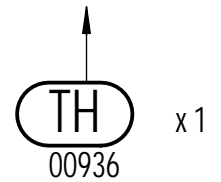
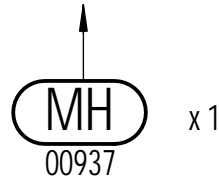
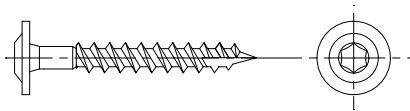

(P17) x17

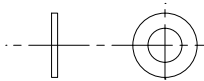

(OS1) x4

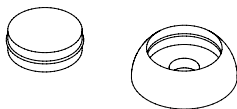

(W20) x4

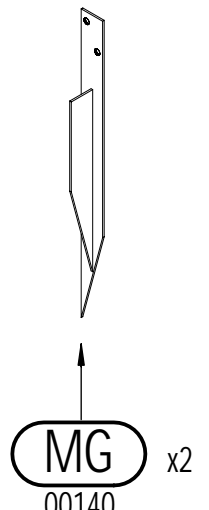
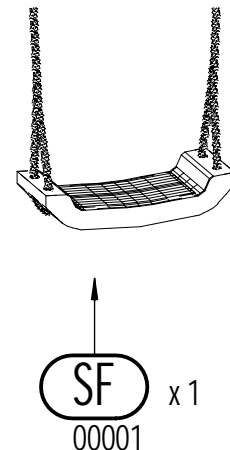
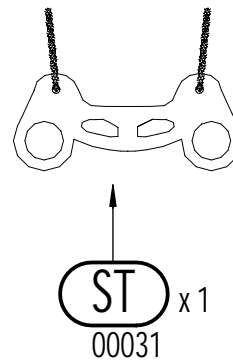
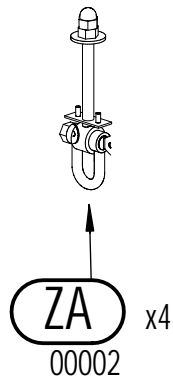
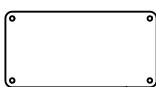
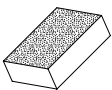

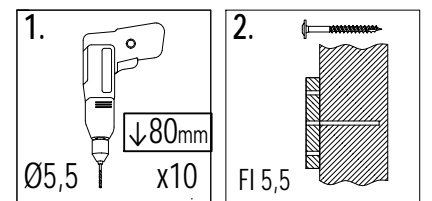
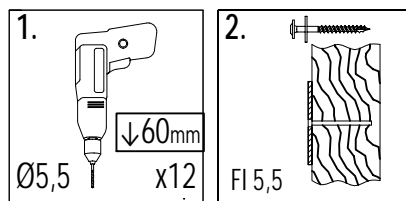
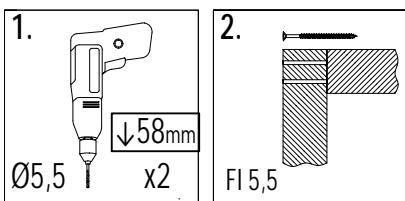
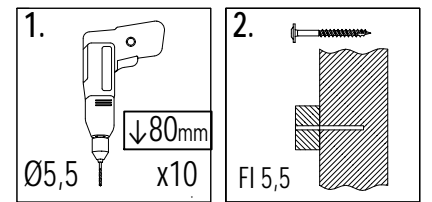
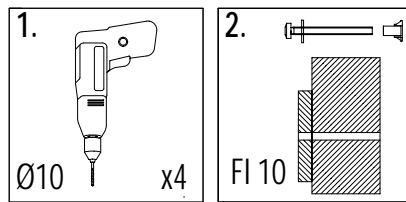
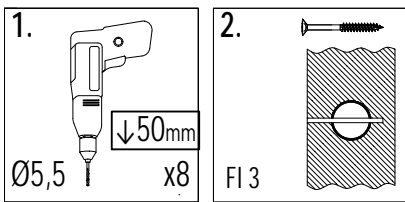
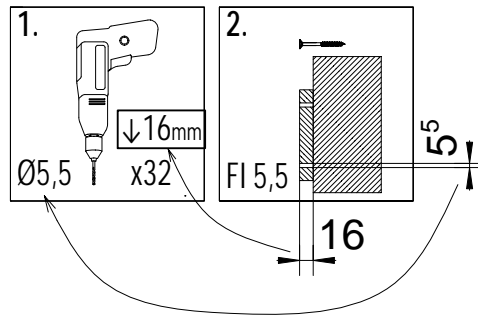
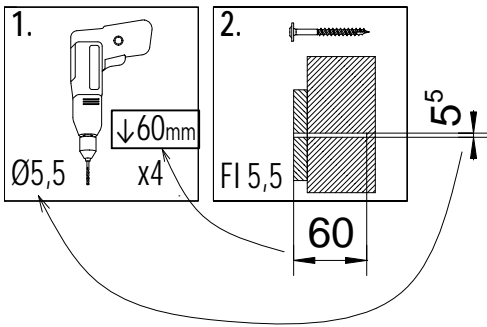
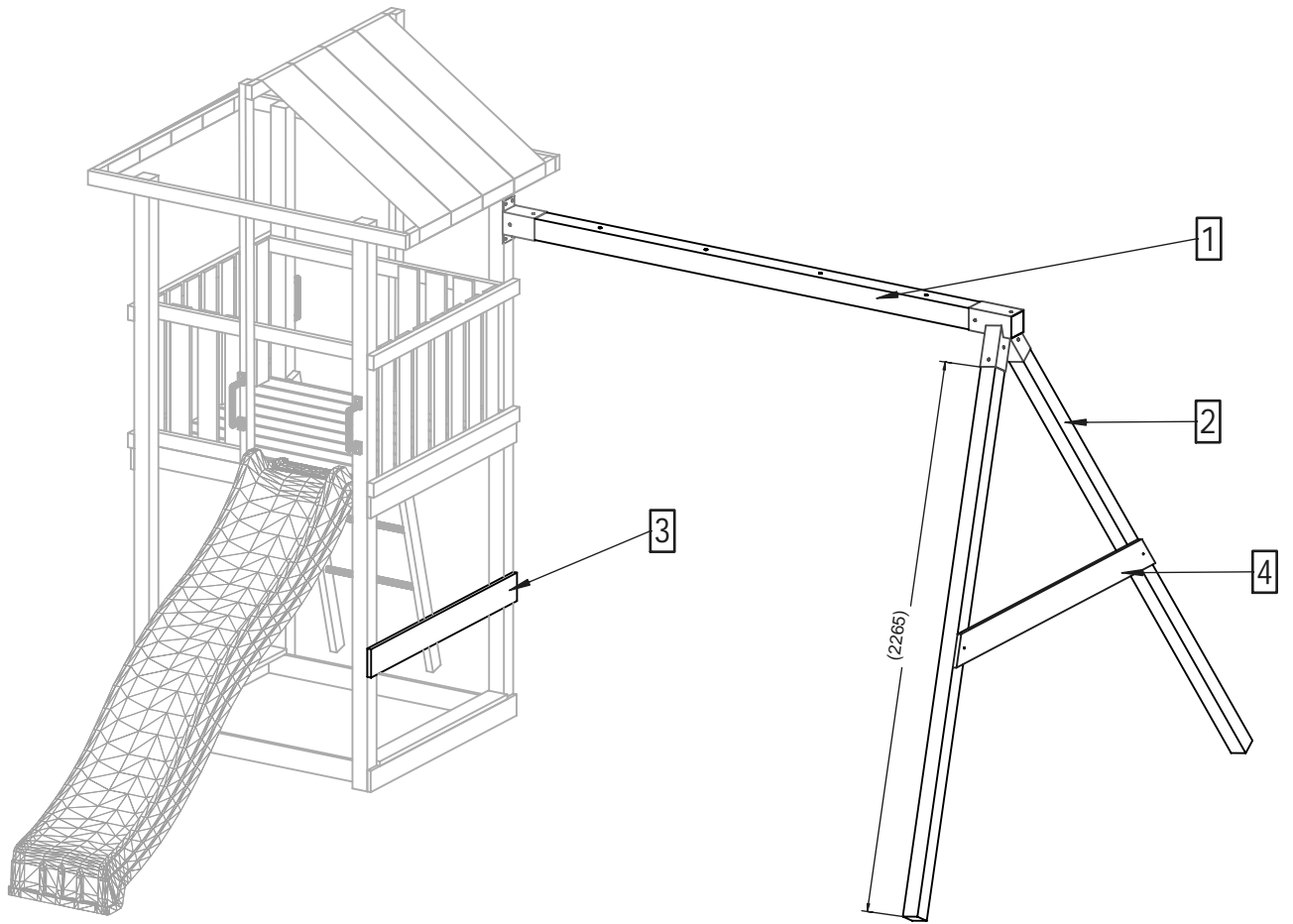

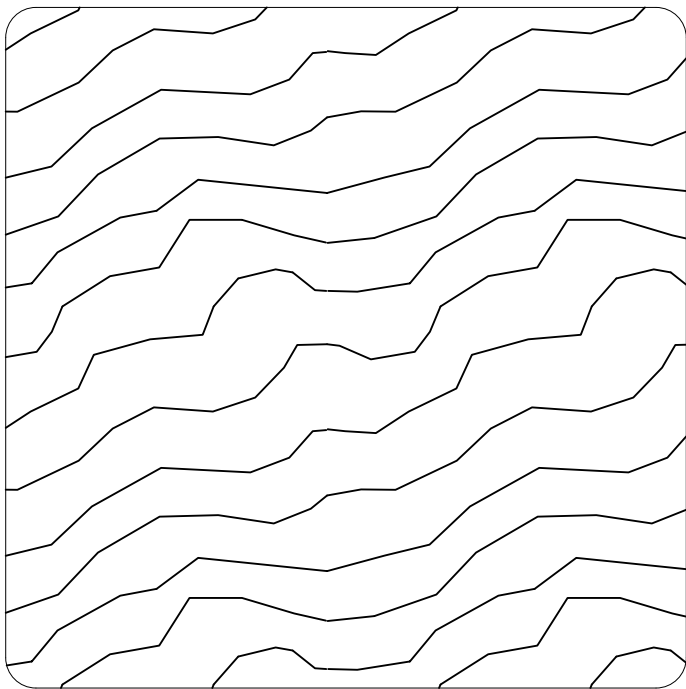

9,0 x 9,0 cm

Lp.	Kod	Wymiary [mm]	szt.
1a	06335	90x90x2400mm	1

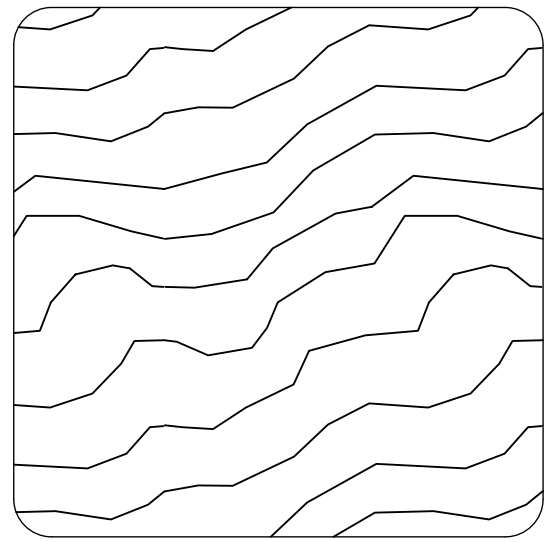

7,0 x 7,0 cm

Lp.	Kod	Wymiary [mm]	szt.
2	04405	70x70x2400mm	2

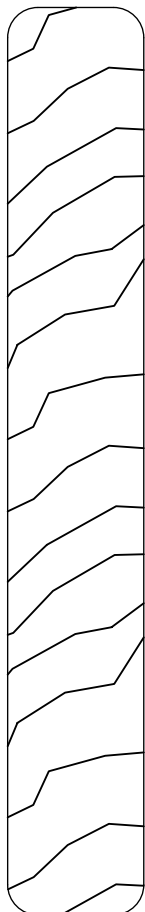

1,8 x 12,0 cm

Lp.	Kod	Wymiary [mm]	szt.
3	01418	18x120x1600mm	1
4a	00133	18x120x1500mm	1

1a

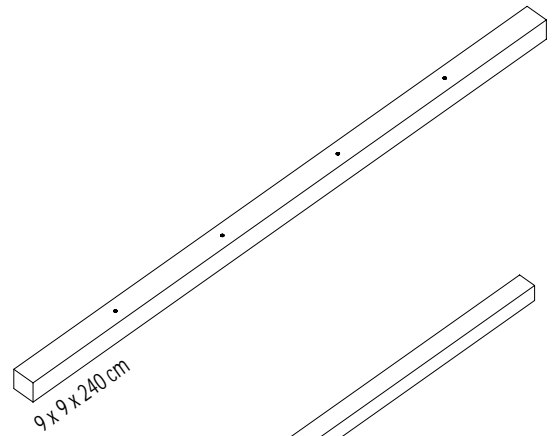

2

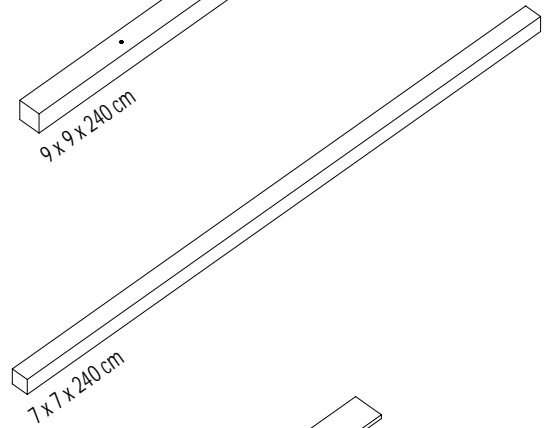

3

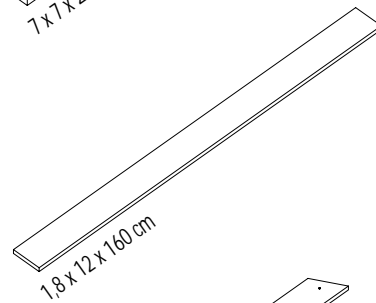

4a

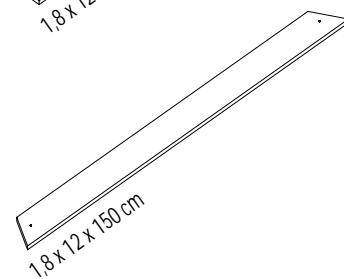

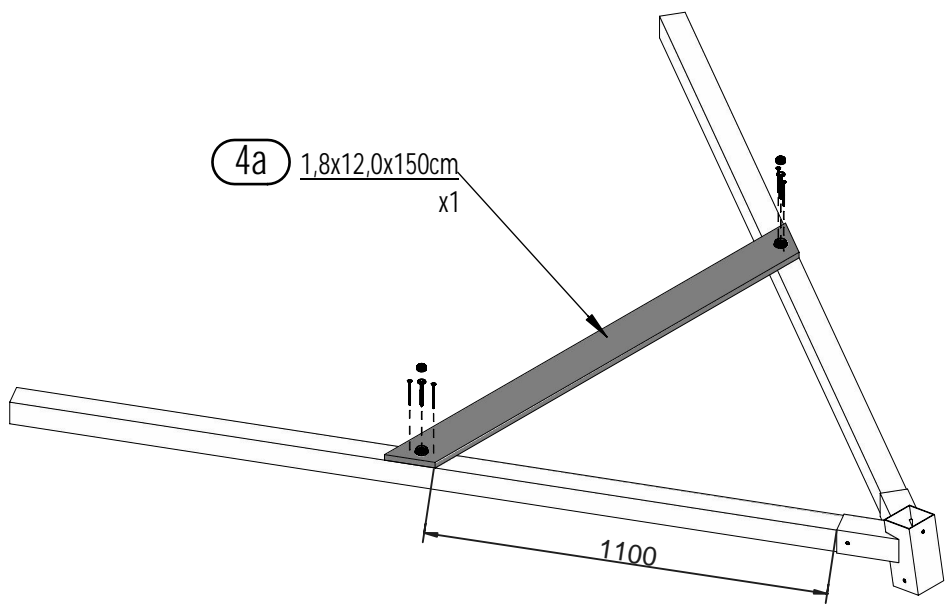
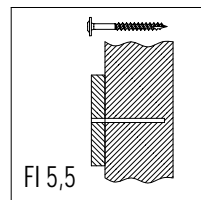
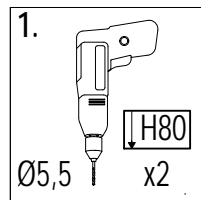
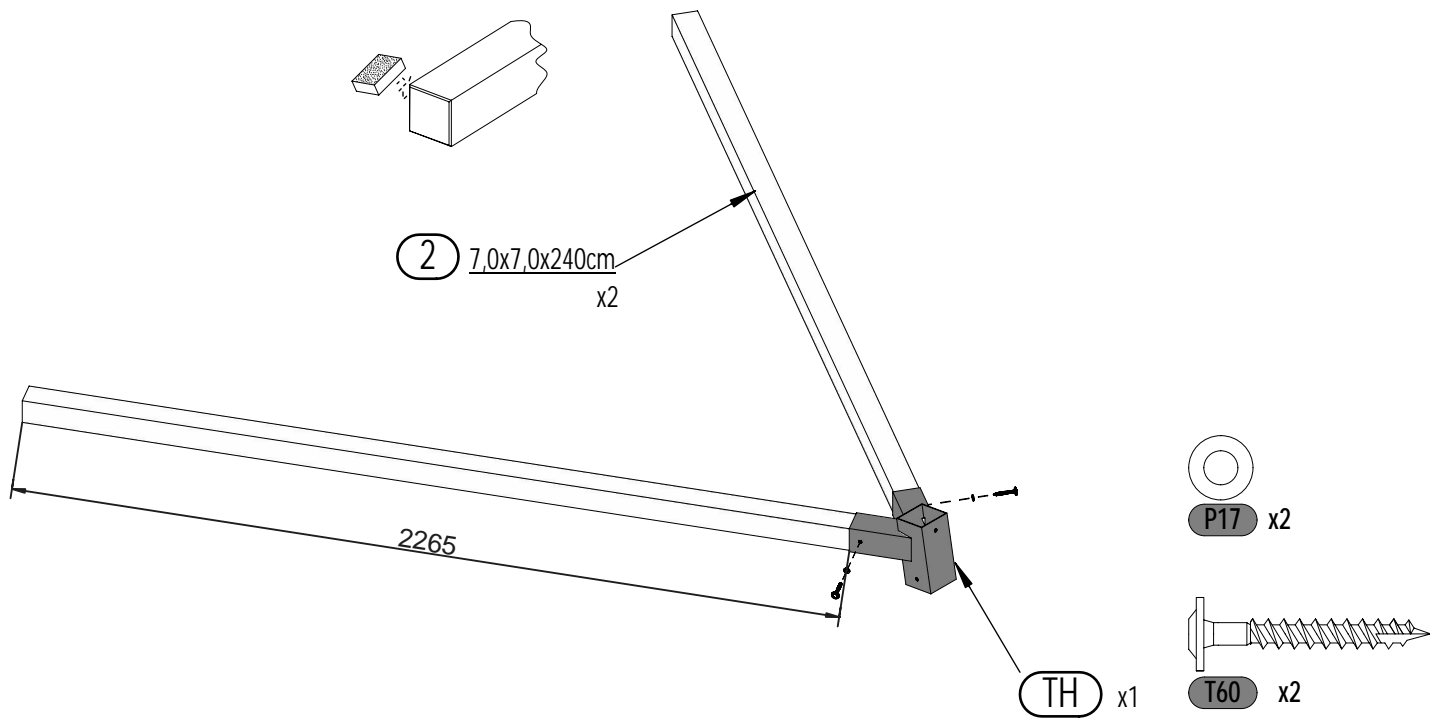

03

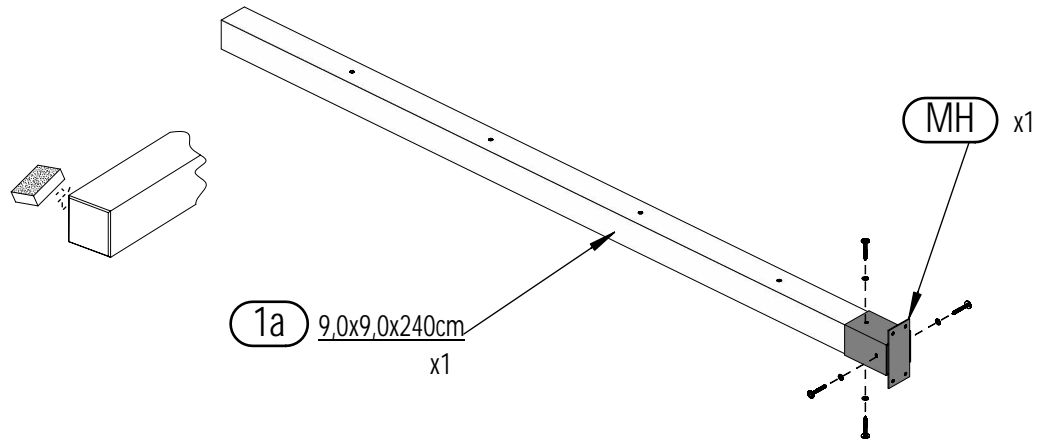

P17 x4



T60 x4

04

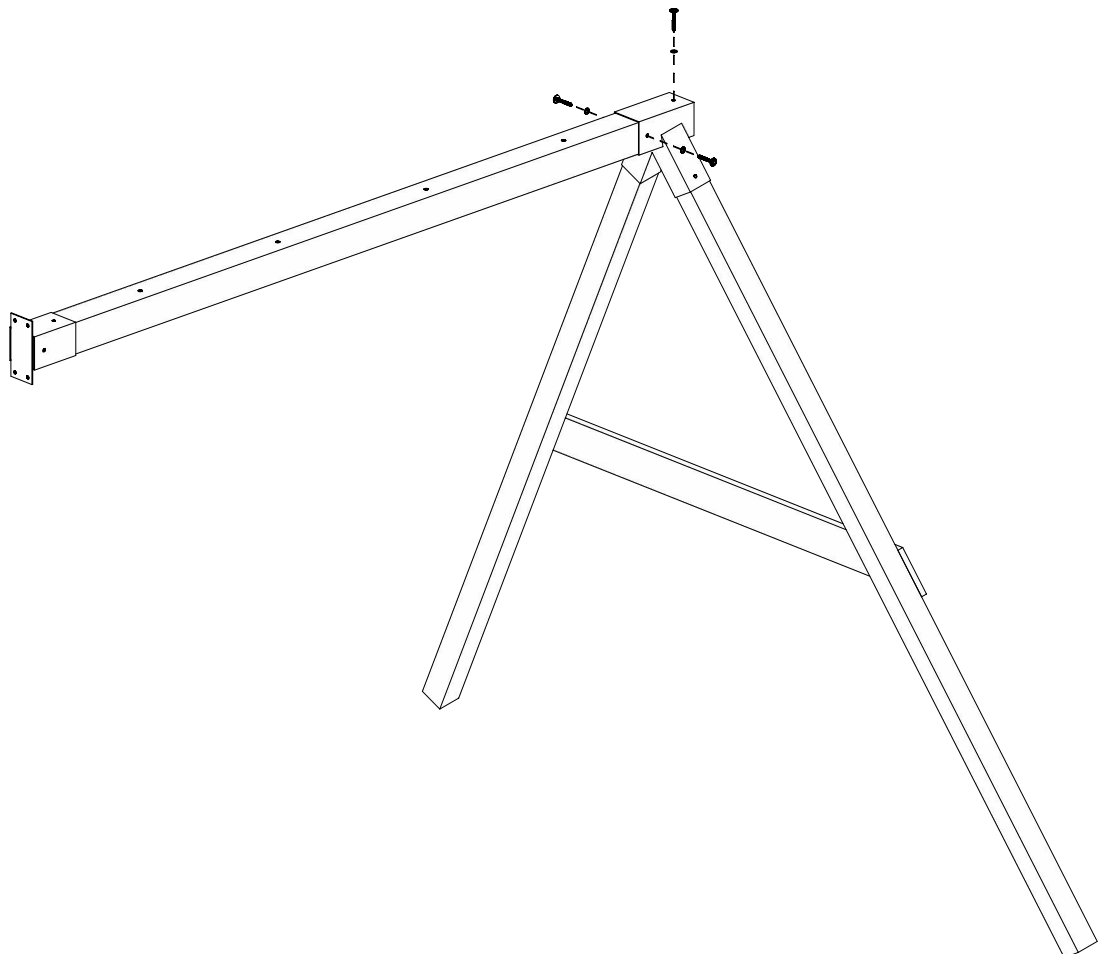

P17 x3

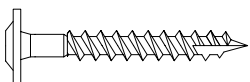

T60 x3

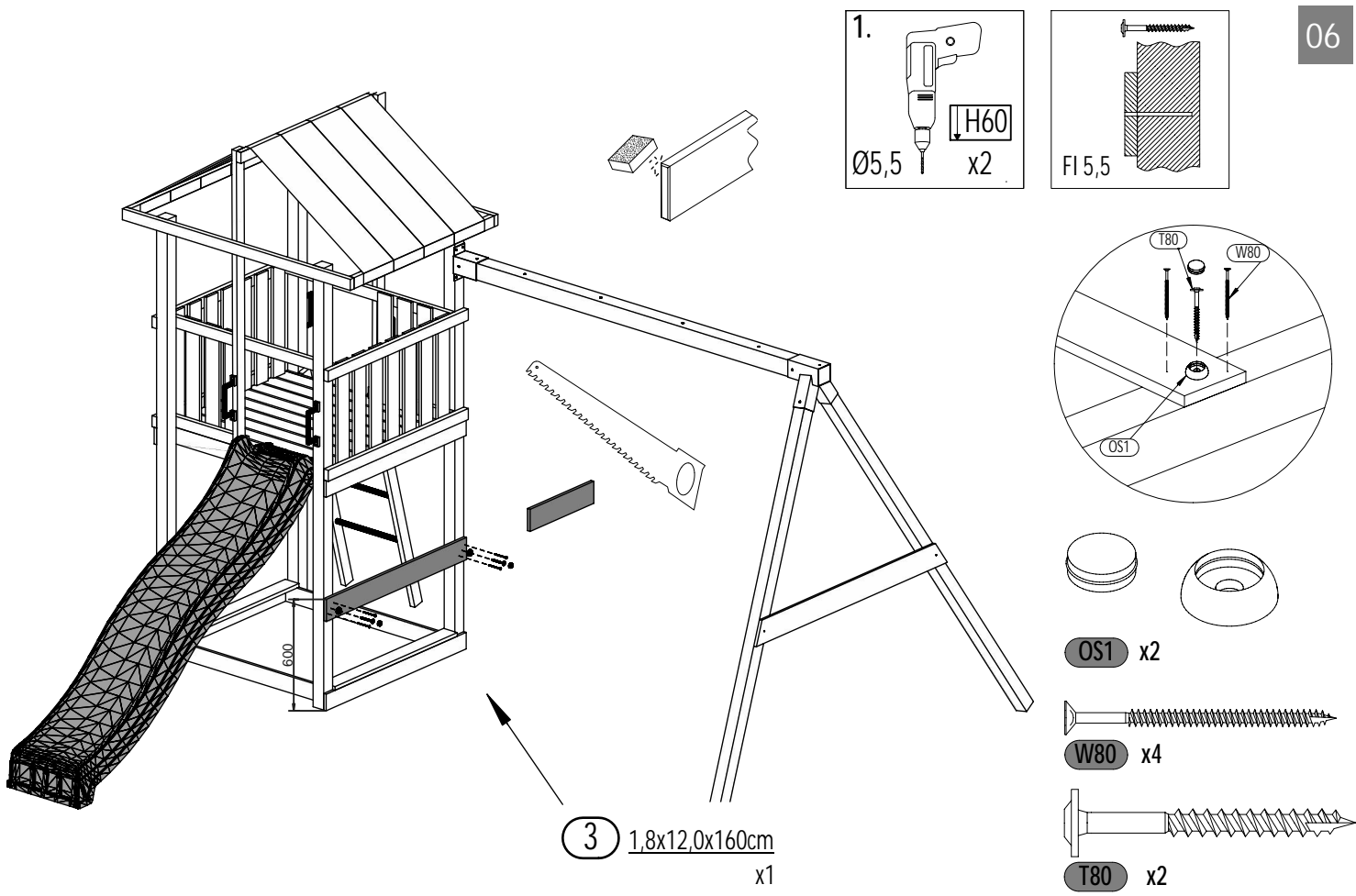
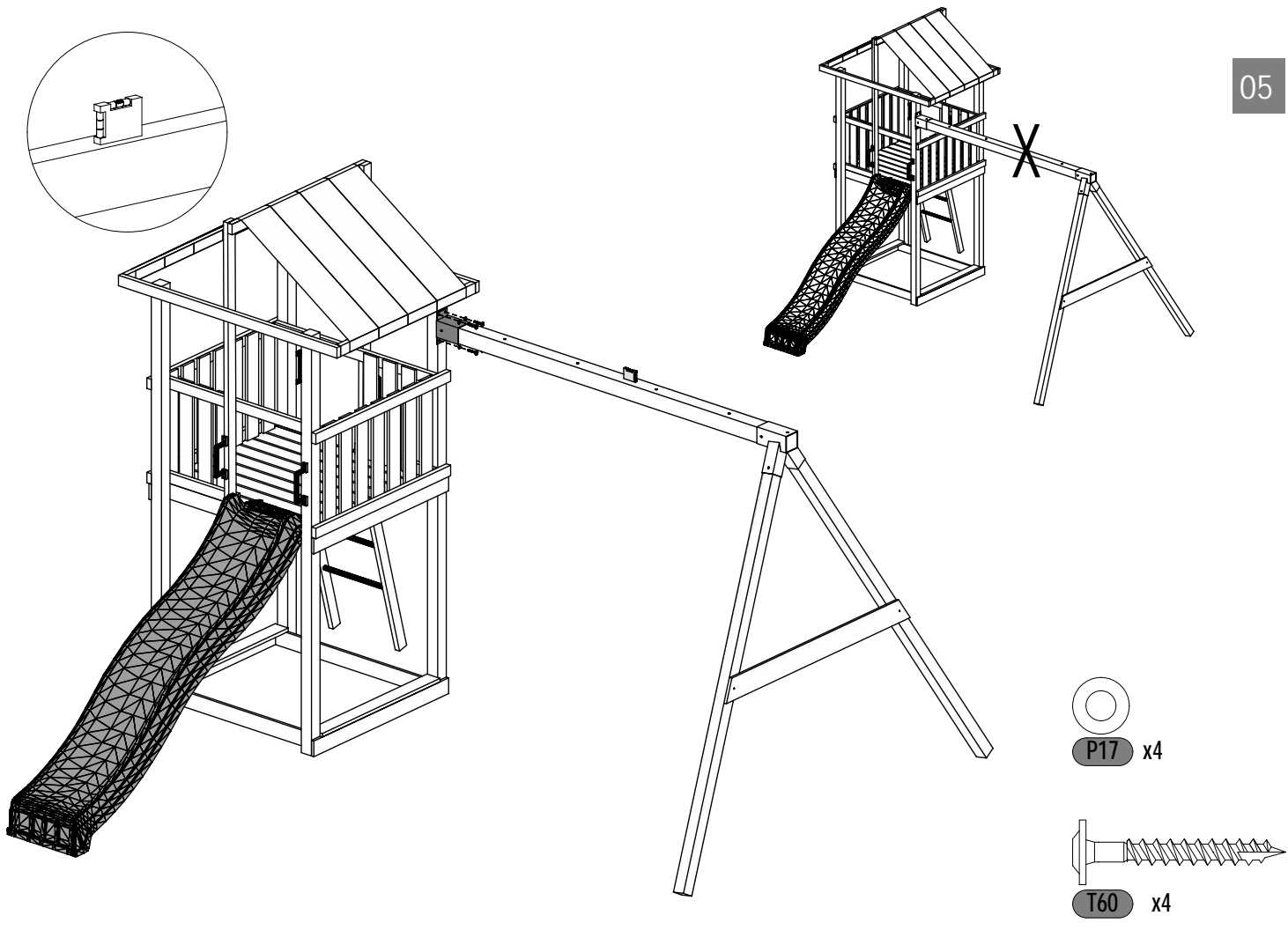

Zgodne z normą PN-EN 71 stosuj zalecenia producenta odnośnie odległości oraz metody mocowania poszczególnych elementów
 In compliance with the standard PN-EN 71, apply guidelines of the producer in relation to distances and methods of fastening individual elements

07

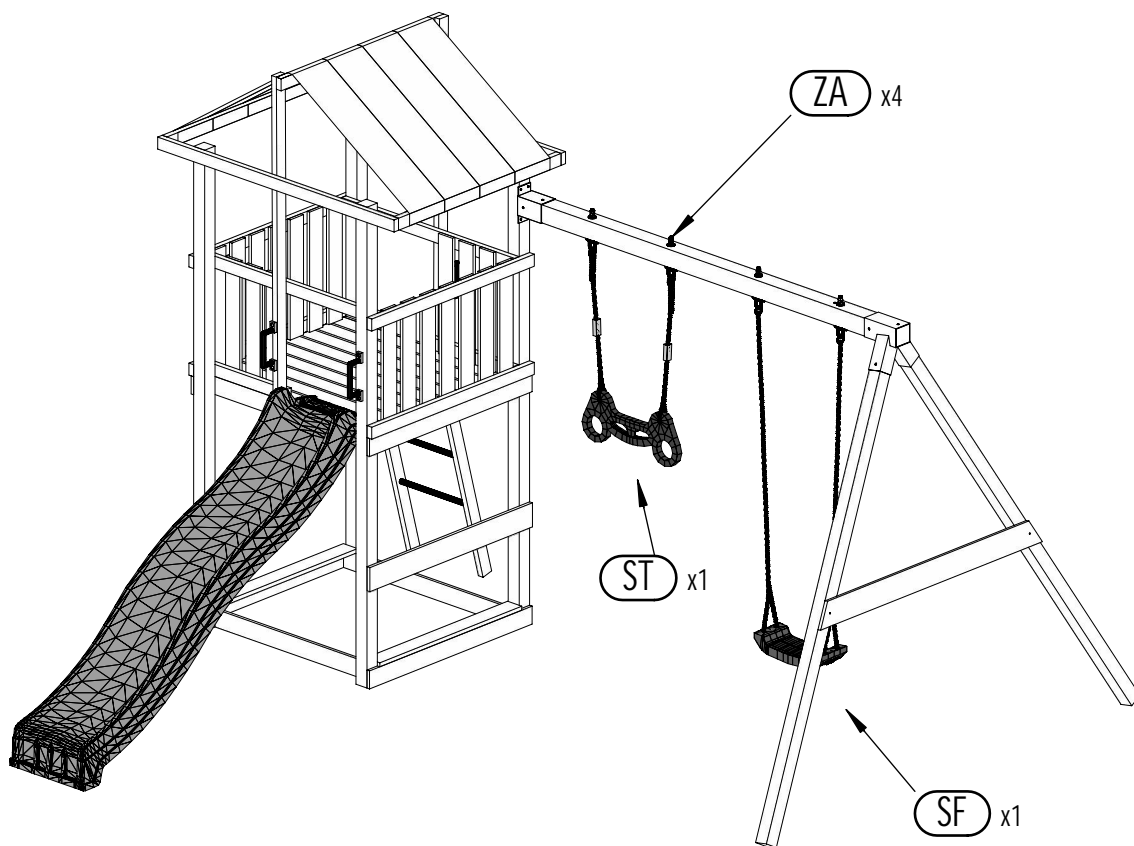

08

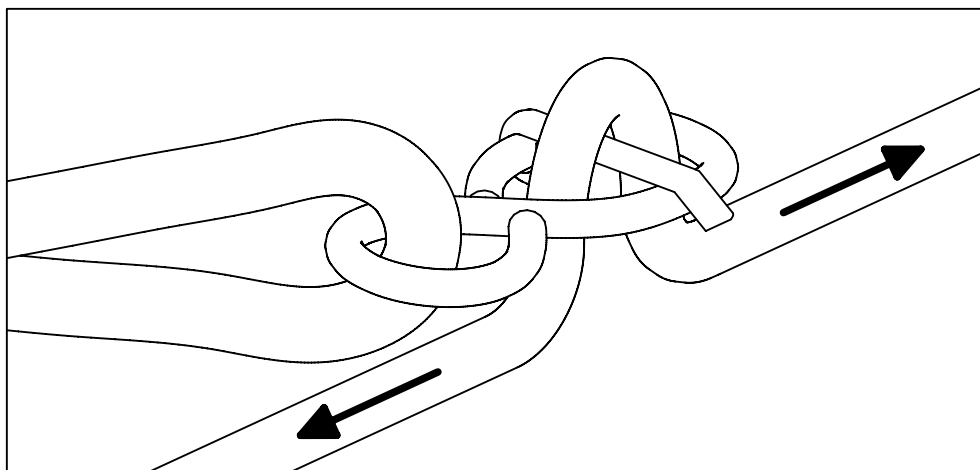

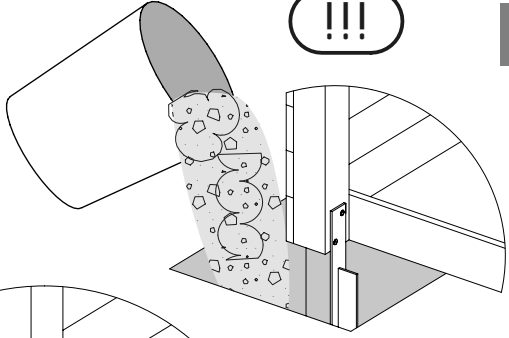
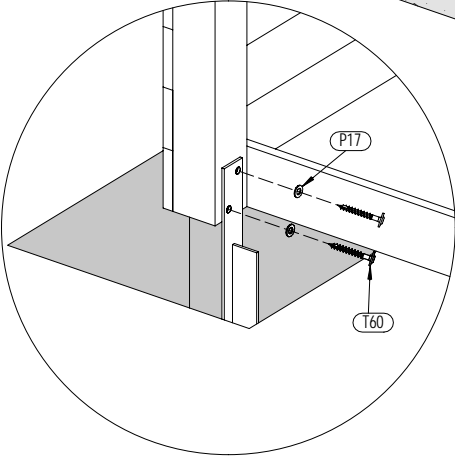
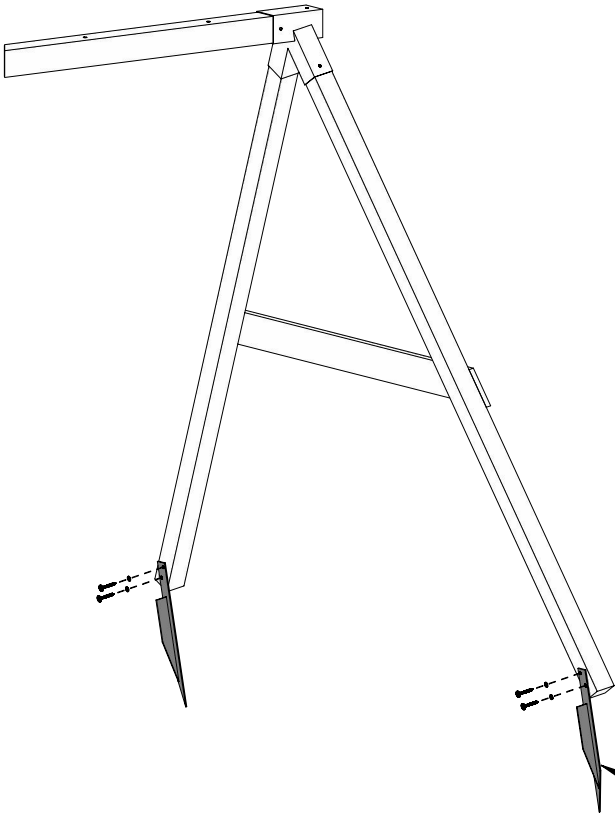

MG x2

P17 x4

T60 x4

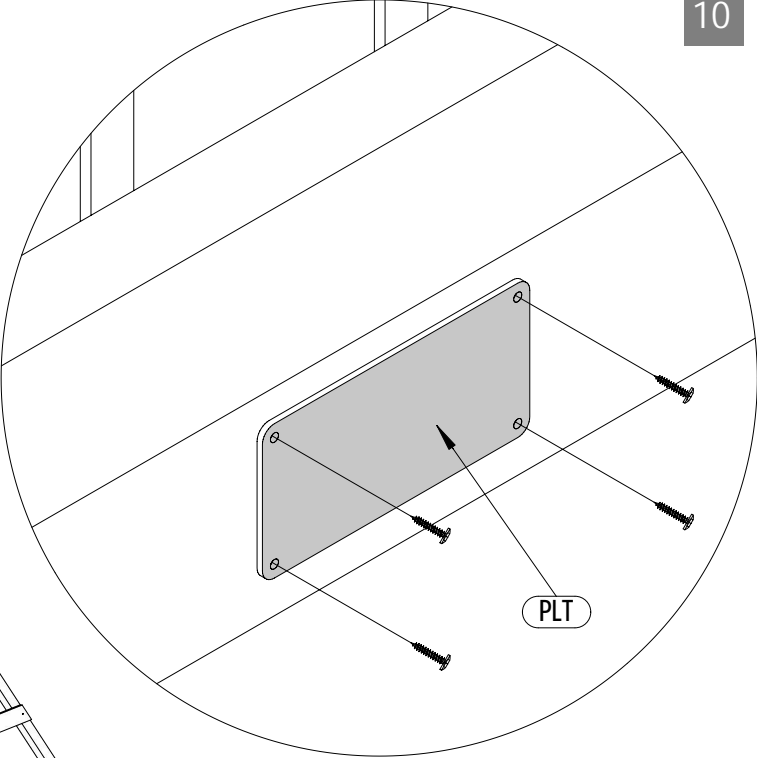
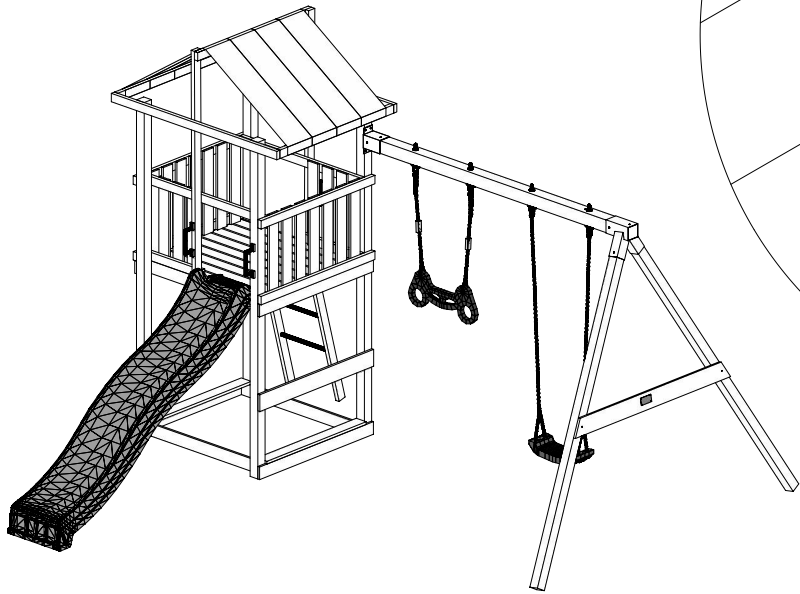

PLT

W20 x4

Zgodne z normą PN-EN 71 stosuj zalecenia producenta odnośnie odległości oraz metody mocowania poszczególnych elementów
In compliance with the standard PN-EN 71, apply guidelines of the producer in relation to distances and methods of fastening individual elements